

BIRO[®]

Our Equipment Works Harder So You Don't Have To

Increase your yield and make a better product with the Biro Model VTS-500 Vacuum Tumbler. The three stage timer lets you program relax time into your tumbling cycle for products such as hams or bellies. The heavy duty casters let you do your tumbling virtually anywhere in your plant, and the drain hole in the drum makes cleanup a snap. Run/jog controls let you position the drum for easy cleaning or unloading, and a lug on a cart fits nicely under the drum for easy unloading. Of course, we've made sure that the new Biro Model VTS-500 has a vacuum pump that can evacuate the drum quickly, so you don't have to sit around and wait. All of this means that the Biro Model VTS-500 works harder so you don't have to.



EXTERNAL MOISTURE TRAP
NOT SHOWN

VTS-500



*Stands alone for quality
and value since 1921*

SPECIFICATIONS

MODEL VTS-500 VACUUM MARINATING TUMBLER.
ELECTRICAL 3/4 HP, 115 VOLTS, 60 CYCLE, 1 PHASE
 8' CORD AND PLUG, CONTROLS NEMA 4X RATED.
CONSTRUCTION STAINLESS STEEL DRUM AND FRAME.
MOTORS

CONTROLS ARE NEMA 4X RATED

MOTOR	HP	TYPE	KW	VOLTS	AMPS	HERTZ	PHASE	CODE
DRIVE	%	TEFC	.56	115/230	12/6	60	1	STD
PUMP	%	OPDP	.56	115/230	12/6	60	1	STD
DRIVE	%	TEFC	.56	220	7	50	1	EC
PUMP	%	OPDP	.56	220	7	50	1	EC

STD=STANDARD OP=OPTIONAL EC=EXTRA COST
 TEFC= TOTALLY ENCLOSED FAN COOLED OPDP=OPEN DRIP PROOF

DRUM CAPACITY 500 LBS. (227 KG). TUMBLE 440 LBS. (199 KG) APPROXIMATE.
DUMP HEIGHT 24" (609 MM), DRUM OPENING AT 9 O' CLOCK POSITION.
DRIVE MOTOR 3/4 HP (.56 KW).
 VARIABLE SPEED (0-14) RPM.
 60:1 TRANSMISSION.
 TEFC (TOTALLY ENCLOSED FAN COOLED).
VACUUM PUMP 3/4 HP (.56 KW) 60 CYCLE, 1 PHASE.
TIMER 99 MINUTE PROGRAMMABLE REPEAT CYCLE
 TIMER (RUN-STOP-RUN).
TUMBLE SPEED 0-14 RPM.
SAFETY STANDARD PHOTO ELECTRIC EYE FOR SAFETY SHUT DOWN.
STANDARD FEATURES 5" LOCKING SWIVEL CASTERS, DRAIN CAP WRENCH,
 EXTERNAL MOISTURE TRAP WITH REMOVAL TOOL, INTERNAL IN-LINE FILTER
 3 EXTRA FILTER ELEMENTS, 8' CORD AND PLUG 115 V, 8' CORD NO PLUG 220 V, 4 ADJUSTABLE QUICK RELEASE
 TOGGLE CLAMPS ON LID, SILICONE LID GASKET, OPERATING AND SAFETY MANUAL.
OPTIONS (EC) 220-50-1 OR 220-60-1, LEG EXTENSIONS, STAINLESS STEEL LOCKING SWIVEL CASTERS AND BALL BEARINGS,
 REVERSE SWITCH MOMENTARY, TIME INHIBITOR (MEMORY), STAINLESS STEEL CRIMPED FITTINGS ON HOSE,
 1 HP CONTINUOUS DUTY VACUUM PUMP.
CERTIFICATION U.L.
WEIGHT UNCRATED: 585 LBS. (265 KG) APPROXIMATE.
 CRATED: 675 LBS. (306 KG) APPROXIMATE.
DIMENSIONS CRATED L = 46" (1168 MM), X W = 42" (1067 MM), X H = 57" (1448 MM)

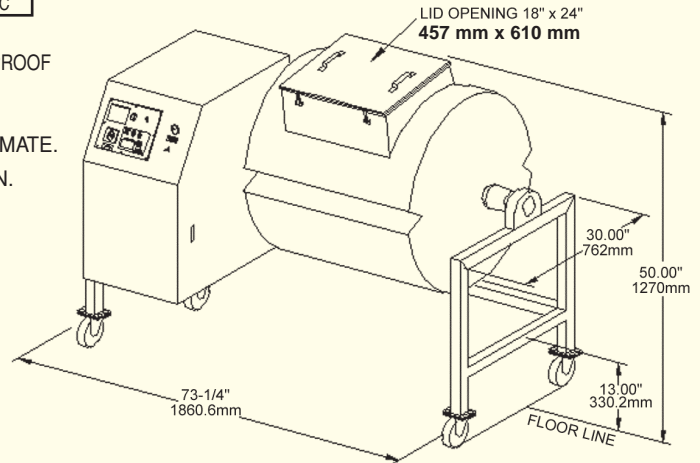

THE BIRO MANUFACTURING COMPANY
 1114 WEST MAIN STREET
 MARBLEHEAD, OH 43440-2099 U.S.A.
 Phone: (419) 798-4451
 Fax: (419) 798-9106
<http://www.birosaw.com>
sales@birosaw.com

ALL SPECIFICATIONS CONTAINED HEREIN ARE SUBJECT TO CHANGE WITHOUT NOTIFICATION.

ITEM NO.: LIT VTS-500-306
 FORM NO.: Md VTS-500-306-9-06-4-ENG-MARK

Service is available from over 245 locations worldwide